



# V- Series

## Sit-Down Counterbalanced

Versatility of use due to compact design and minimal operating space requirements. Compact dimensions combined with superb maneuverability.



### CAPACITY

V-15 2800 lbs. at 24" load center  
V-18 3500 lbs. at 24" load center

### BATTERY

V-15 Battery compartment: 32" x 19" x 24"  
V-15 Minimum battery weight 1520 lbs.  
V-18 Battery compartment: 32" x 23" x 24"  
V-18 Minimum battery weight 1760 lbs.

No cover Anderson 350 Blue-A22

### PERFORMANCE

48 volt batteries with 400-600 Ah capacity  
ZAPI AC lift and travel control.

### GRADEABILITY

14.5% - unloaded / 10.5% - loaded.

### TRAVEL

9.1 mph empty  
8.12 mph loaded

### LIFT

Up to 110 fpm empty  
Up to 61 fpm loaded

### LOWERING

Up to 85 fpm empty.  
Up to 105 fpm loaded

### TIRES

FRONT DRIVE X 2  
18" x 7.8" solid pneumatic  
DUAL STEER TIRE  
15" x 4.62" solid pneumatic

### OPERATOR COMPARTMENT

Ergonomic roomy cab, wide view mast, hydrostatic power steering with spinner knob, adjustable steering column and adjustable suspension seat ensures comfortable working position. Hydraulic controls: lift/lower, tilt, and load side-shift within easy reach of operator.

Large "wide view" reversing mirror increases operation efficiency. Side hand rail aids operator comfort in reverse driving position.

### ELECTRICAL

AC technology fitted to heavy-duty applications. Electrical current is optimized and AC motors are brushless, which minimizes servicing. "neutral braking" eliminates truck roll-back and allow higher travel speeds. Diagnostic display with thirty performance travel and lift parameters can be adjusted to suit all types of loads, working condition's area and operator driving skill.

### HYDRAULICS

Powerful AC hydraulic lift motor provides smooth high torque lifting and lowering. Hydraulic lift and drive components are sealed against dirt and water protecting them from contamination.

### DRIVE UNIT AND BRAKES

Dual drive motors offer great maneuverability. The incorporation of ZF® developed components, including finely engineered helical gears, assured low noise, high quality and a long service life with low maintenance.

The "V" series three-wheel truck has three independent braking systems: regenerative "neutral braking", hydraulic wet disc braking, and toggle-type parking brake.

### FRAME AND MAST

High stability chassis with long wheelbase, wide tires and low center of gravity. "See Thru" integral side-shift with load back rest (LBR). Wide view mast, low scuttle and high seating position gives the operator an excellent view, reducing load damage and accidents. Fully enclosed chassis weldment house the dual drive motors.

### SERVICEABILITY

The state-of-the-art controller can be easily accessed at waist height, reducing service time. Uncomplicated removable side battery compartment allows battery maintenance.

### STANDARD EQUIPMENT

- Headlights and Brake Lights
- Yellow Flashing Light
- Solid Pneumatic Tires
- Dual Steer Tire
- Integral Side-Shift
- Ergonomic Operators Compartment



Operators View

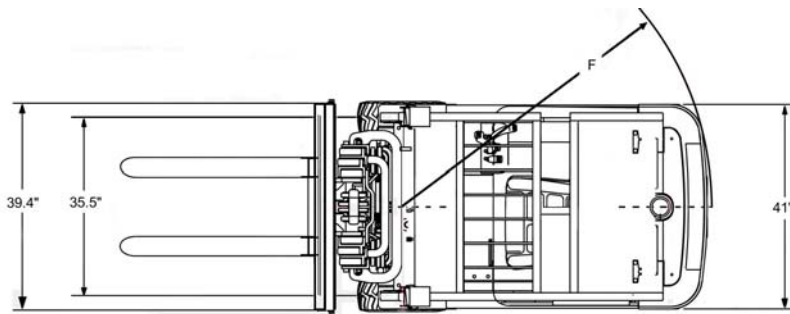
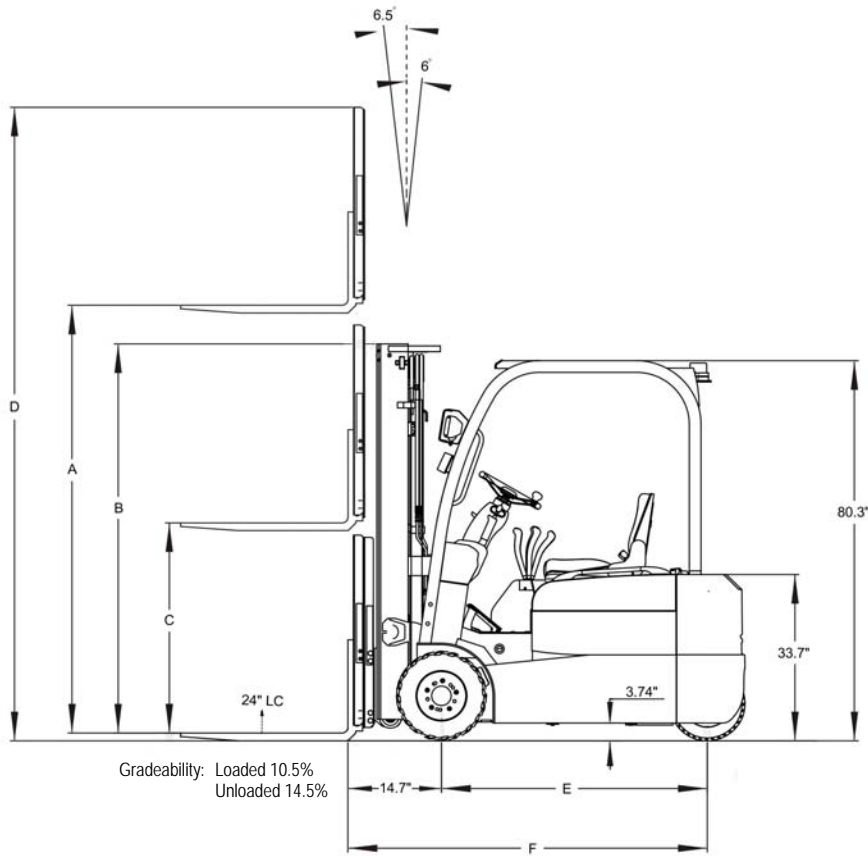

### RATED CAPACITY

- V-15  
2800 lbs. to 118" @ 24" LC  
2000 lbs. to 189" @ 24" LC
- V-18  
3500 lbs. to 118" @ 24" LC  
2479 lbs. to 189" @ 24" LC

Model #	Lift Height	Col Height	Free Lift		Extended Height		Wheel Base	Turning Radius	Length to Face of Forks	Weight (lbs)
			Without Backrest	With Backrest	Without Backrest	With Backrest				
	A	B	C		D		E	F	G	
<b>2800 lbs Capacity @ 24" Load Center</b>										
V15-188	189	85	62	48	214	226	49.6	53.5	72.0	6720
<b>3500 lbs Capacity @ 24" Load Center</b>										
V18-188	189	85	62	48	214	226	57.2	61.1	76.0	6960

<sup>3</sup>Estimated shipping weight with battery