

VNA PROPANE EQUIPMENT DAILY CHECKLIST



DATE	<input type="text"/>	INSPECTED BY	<input type="text"/>
MAKE	<input type="text"/>	MODEL	<input type="text"/>
		S/N#	<input type="text"/>
HOUR	<input type="text"/>	PROPANE	<input type="text"/>

MARK BOX If NO PROBLEMS Visible. KEEP UNMARKED and WRITE IN Comment if PROBLEMS ARE PRESENT.

VISUAL INSPECTION

Comments

1. Tires (Left) _____
2. Forks, Retaining Pin & Heel _____
3. Hydraulic Cylinders _____
4. Tires (Right) _____
5. Dash Display _____
6. Battery _____
7. Engine Compartment _____
 - Oil _____
 - Radiator _____
 - Air Filter _____
 - Fan Belt _____
8. Overhead Gaurd _____
9. Tires (Rear) _____
10. Static Straps _____
11. Propane _____
 - Relief Valve _____
 - Feul Level _____
 - No Leaks _____
 - Safety Strap _____
12. Check Contols _____
 - Lift/Lower _____
 - Tilt _____
 - Side Shift _____
 - Pivot _____
 - Directional Switch _____
 - Speed Selection Switch _____
 - Attachment Switch _____
13. Hydraulic Oil _____
14. Safety Warnings _____
15. Capacity Plate _____

OPERATIONAL INSPECTION

Comments

- A. Investigate Unusual Noises _____
- B. Check Parking Brake _____
- C. Check Service Brake _____
- D. Check Pivot Arm Racking _____
- E. Check Mast Racking _____
- F. Check Accelerator _____
- G. Check Return-to-Neutral _____
- H. Check Seat Switch _____
- I. Check Horn _____
- J. Check Lights & Alarms _____
- K. Check Steering _____
- L. Check Seat Lumbar Side & Pivot _____
- M. Check Seat Belt, Buckle & Retractors _____

SIGNATURE: _____

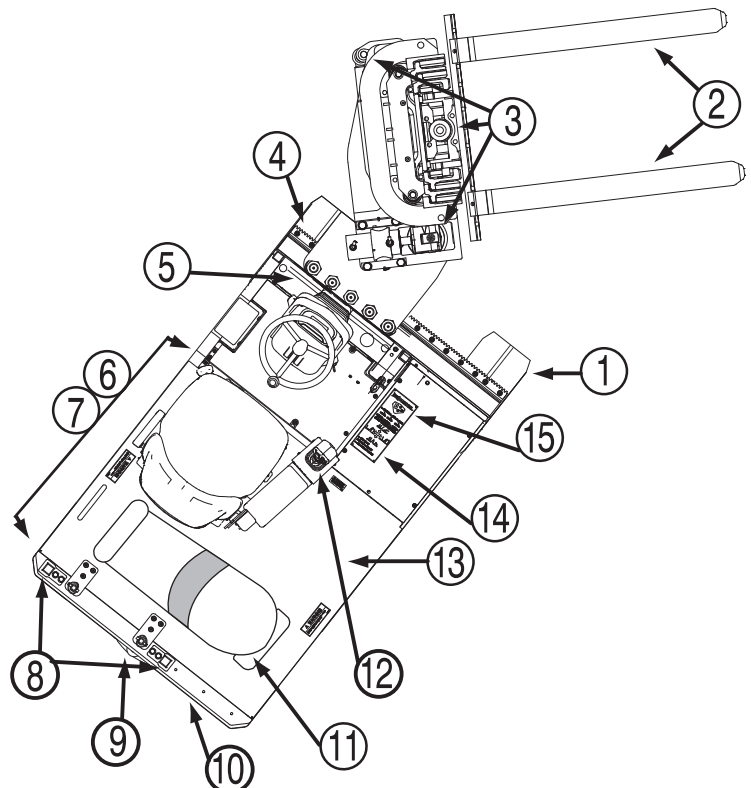

All comments made in reference to any problems should be made on the back of this page in detail and handed to the supervisor immediately.

CAUTION: This is not a complete list of all items which may require attention. Operators are responsible for ensuring that the lift truck is in proper working condition in accordance with the manufacturer's specifications.

DO NOT operate lift truck if a problem is detected.
Report all problems to the service department immediately.